

Flare

High power, energy efficient, impact resistant luminaire.

Suitable for use in multiple locations such as Sports Halls and Low/High Bay applications.

- RAL9016 as standard, other RAL colours available on request.
- Efficacy of upto 135 lm/W
- Suitable for wire suspension, drop rods, chain or surface mounting.
- Various dimming options, including DALI, Switch Dim etc.
- Emergency options available
- Range of colour temperatures 3000K, 4000K & 6000K
- 5 Year Guarantee

Product Code Builder

Type	Description	Code
Product	Flare	Flare
Size	1200	1200
	1500	1500
	1500 Hi	1500Hi
Colour Temperature	Warm White	3K
	Neutral White	4K
	Cool White	6K
Optic	Opal	OP
	UGR19	MPO
Dimming Options	Fixed Output	FO
	Dali	A1
	DSI	A2
	Switch Dim	A3
	1-10v	A4
Emergency	Casambi	A5
	Standard 3 hour	EM3
	DALI/EMPRO	EMD
	Self Test	EMS

Example Code: Flare 1200 3K OP FO EM3



Flare

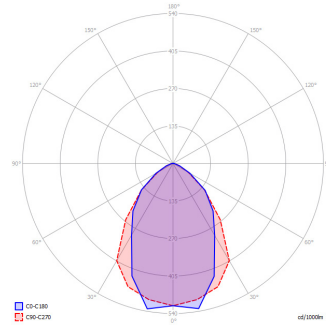
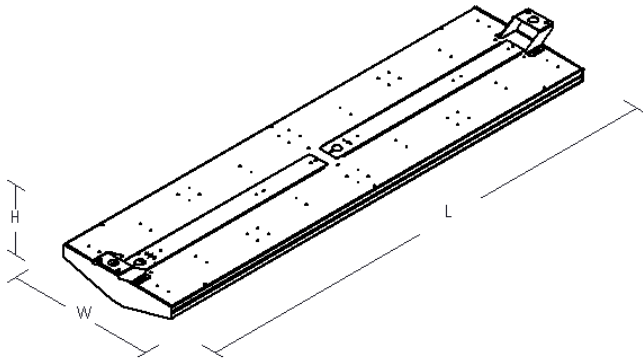

Flare 1200

Product	L x W x H (mm)	Ctt Watts	Luminaire / Lumens	LL / CW	Colour Temp	Ra	Colour Consistency	L70 / B10
Flare 1200	1150 x 300 x 65	126	17,000	135	4000K	>80	SDCM 2	>75K
Flare 1500	1430 x 300 x 65	200	25,000	125	4000K	>80	SDCM 2	>75K
Flare 1500 Hi	1430 x 300 x 65	290	33,000	114	4000K	>80	SDCM 2	>75K