



PAEX-TV2

The TV2 luminaire is available in two wattages designed to replace HID lighting systems up to 175w MH or HPS.

Typical applications include general area, parking, flood, security, and accent lighting for retail centres, industrial parks, schools and universities, public transit and airports, office buildings and medical facilities.

- RAL9005 as standard, other RAL colours available on request.
- IP66 Sealed LED Compartment.
- Mounting heights from 3 to 5 meters.
- Various dimming options, including DALI, Switch Dim etc.
- 5 Year Guarantee



TV2 with Yoke Attachment

Product Code Builder

Type	Description	Code
Product	PAEX-TV2	TV2
Wattage	20W	20
	40W	40
Mounting	Standard	S
	Yoke	Y
Dimming Options	Fixed Output	FO
	Dali	A1
	DSI	A2
	Switch Dim	A3
	1-10v	A4
	Casambi	A5

Example Code: PAEX-TV2 20 S FO



PAEX-TV2

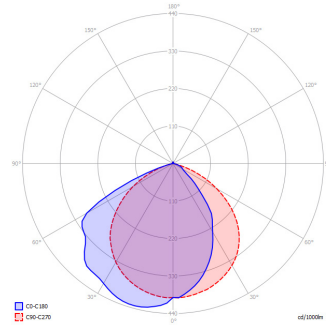
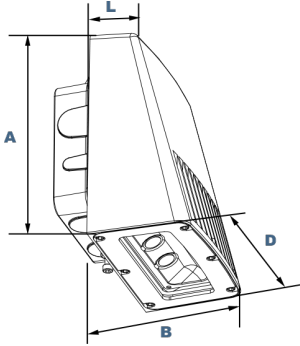

TV2 21W

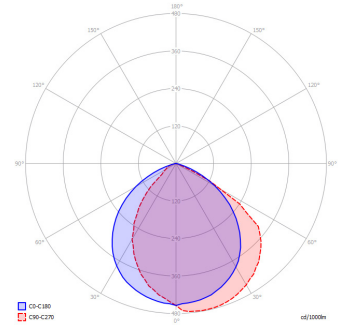

TV2 43W

Product	D x B x A (mm)	Ctt Watts	Luminaire / Lumens	LL / CW	Colour Temp	Ra	Colour Consistency	L70 / B10
PAEX-TV2 20	168 x 200 x 114	21	2300	110	4100K	>80	SDCM 2	84K
PAEX-TV2 40	168 x 200 x 114	43	4025	94	4100K	>80	SDCM 2	84K