

HALO

500/900/1200/1500mm

Suspended feature Luminaire.

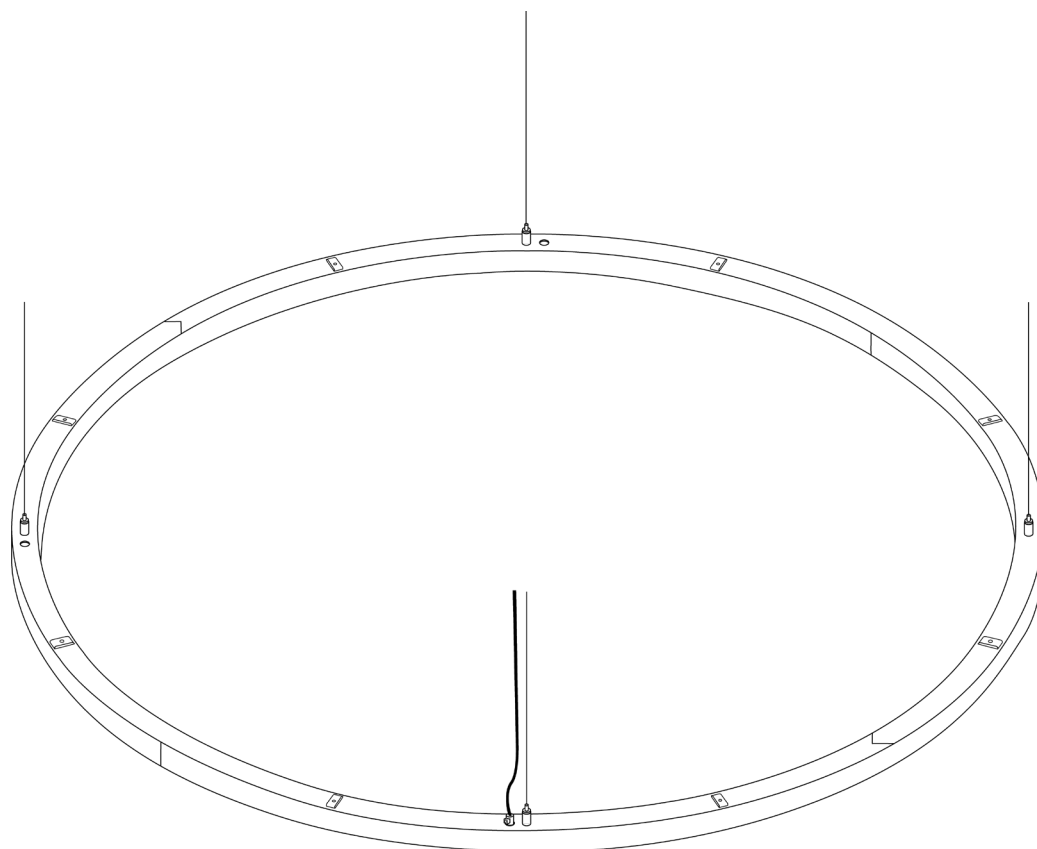

P&A

HALO

As Standard

- Luminaire.
- Pre Installed suspension clutches.
- Pre Installed luminaire flex.
- Remote 24v driver.
- Please check thoroughly before installing and report any missing components.

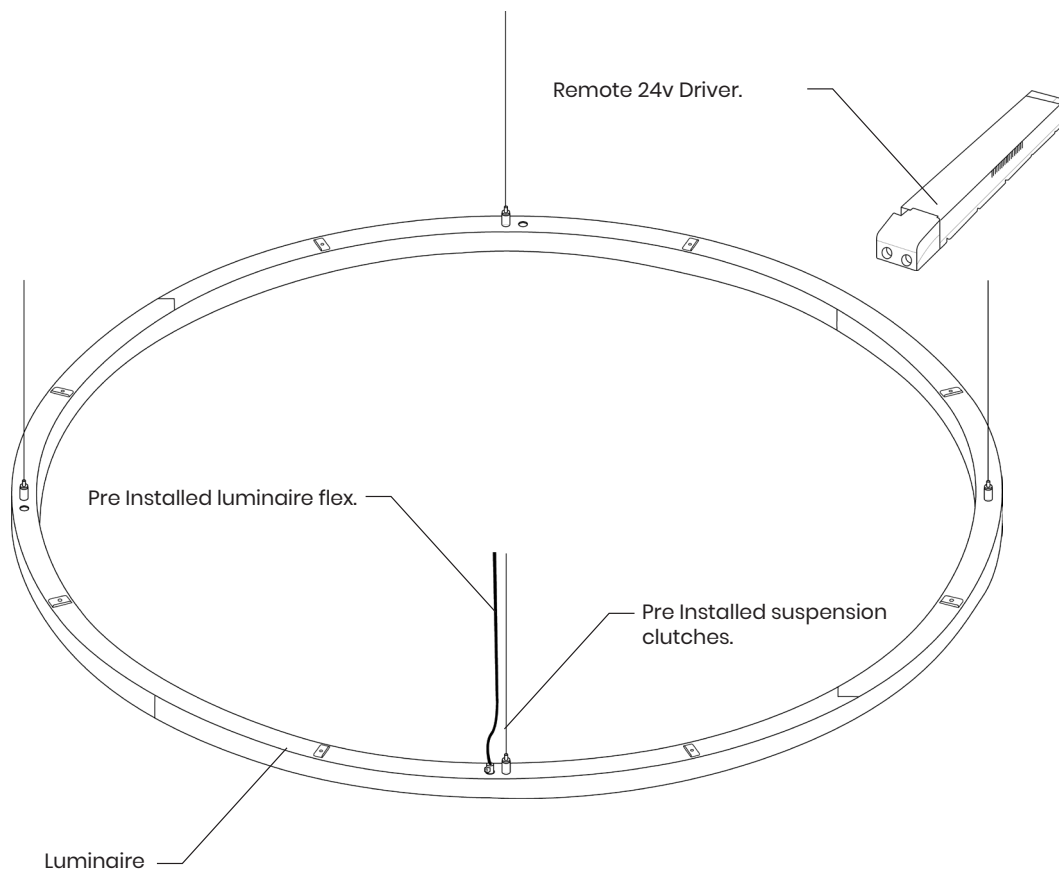

Nominal Diamters				
Products				Suspension Points (No.)
	<i>D</i> Ø	<i>H</i>	<i>Kg</i>	
HALO5	500	30	1.7	3
HALO9	900	30	3	3
HALO12	1200	30	4	4
HALO15	1500	30	5	4

HALO

1

Install female ceiling boss using an M6 Screw.
(Appropriate fixings supplied by others)

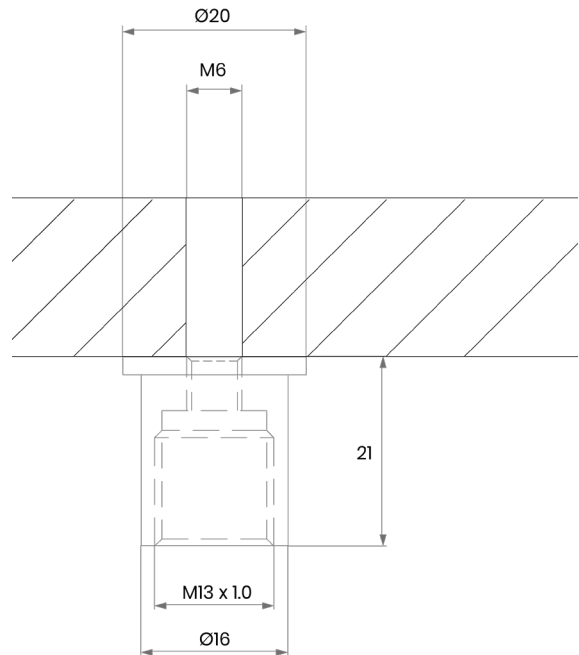
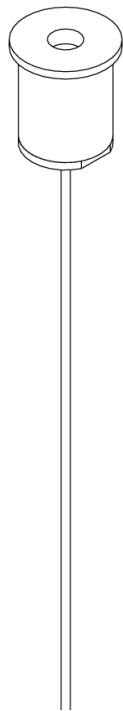

2

A. Thread suspension wire through pre installed suspension clutches. **B.** Pull through suspension, adjust to desired height. Repeat both steps for all clutches/suspension points.

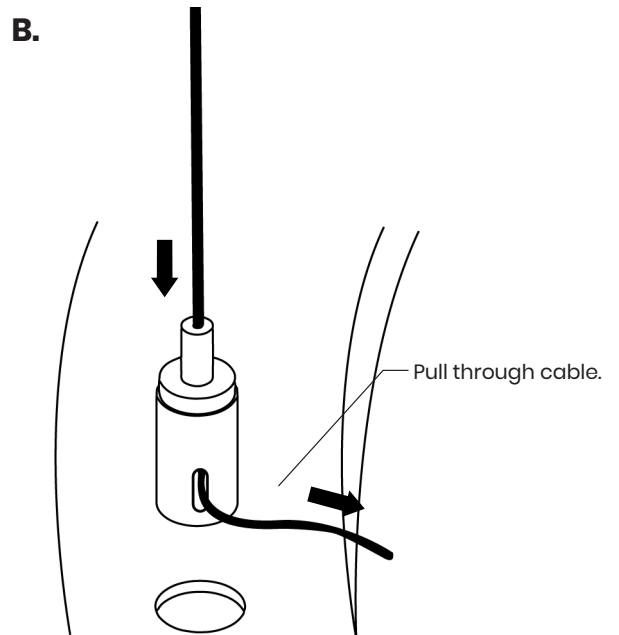
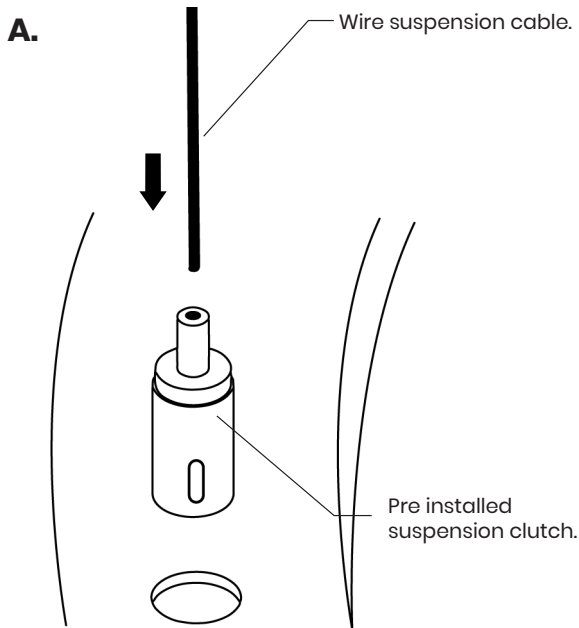

3

Connect pre installed luminaire flex to remote driver.

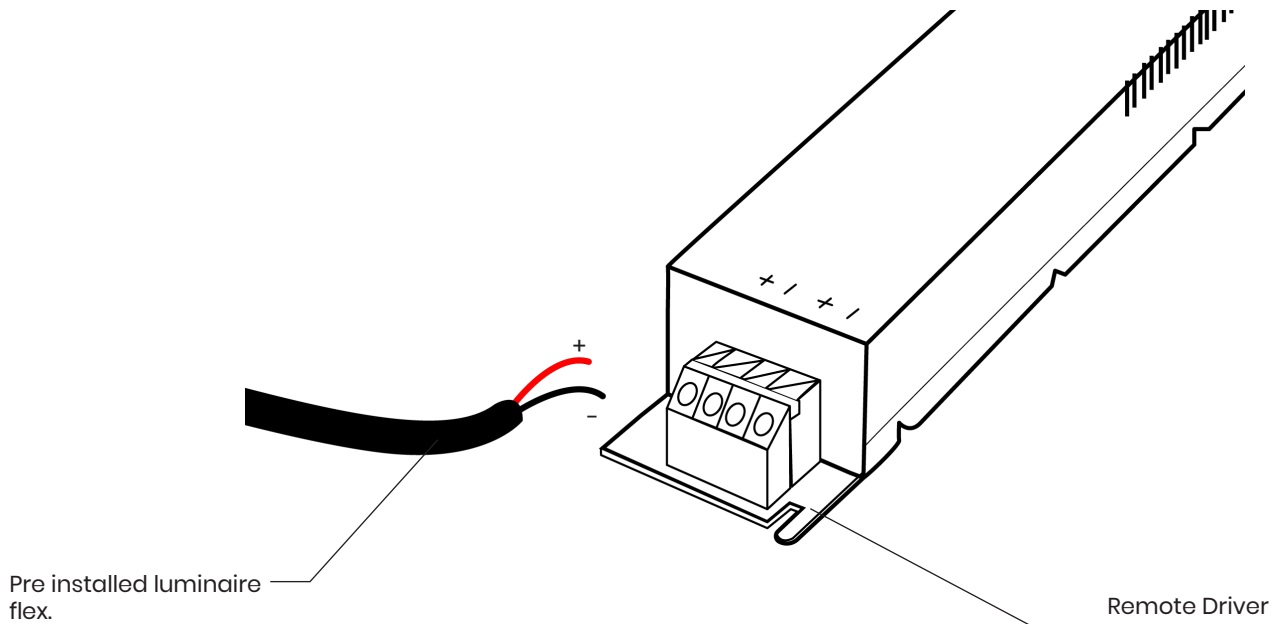

4

A. Connect Incoming supply (provided by others) to driver.
B. Feed driver through into ceiling void (See pages 6-7 for all wiring diagrams).

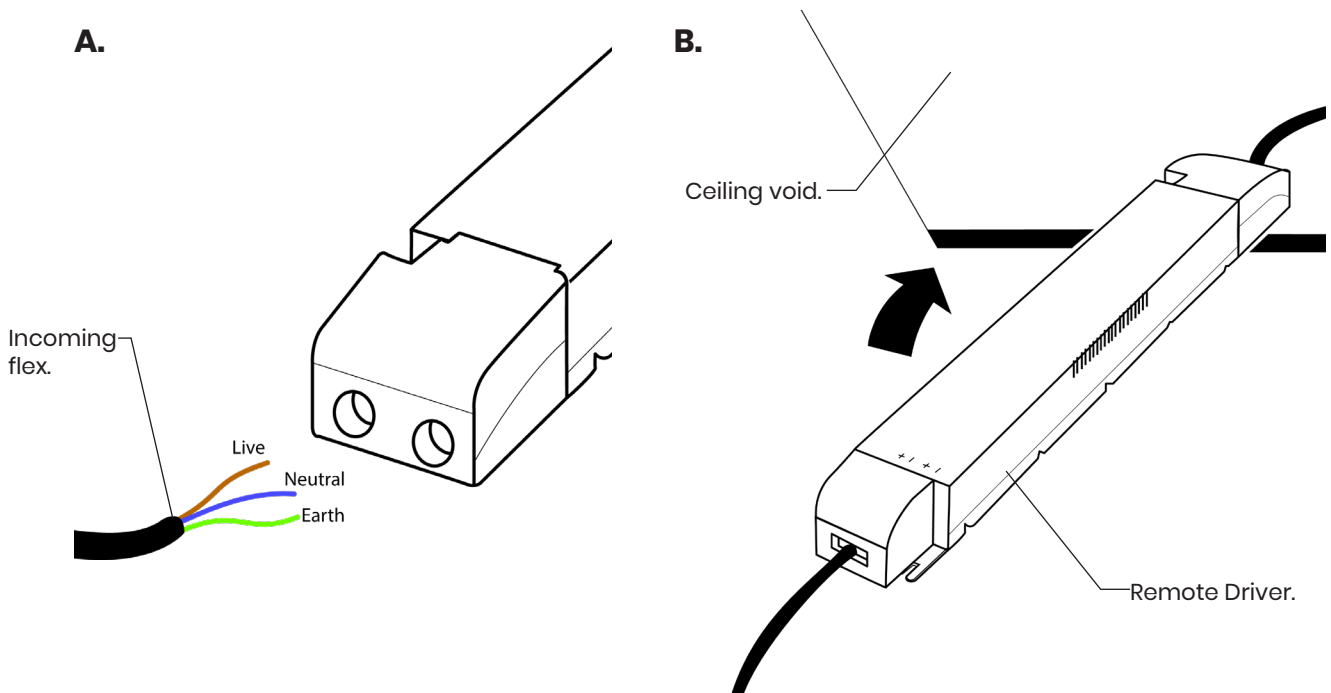

5

Complete installation (Front view).

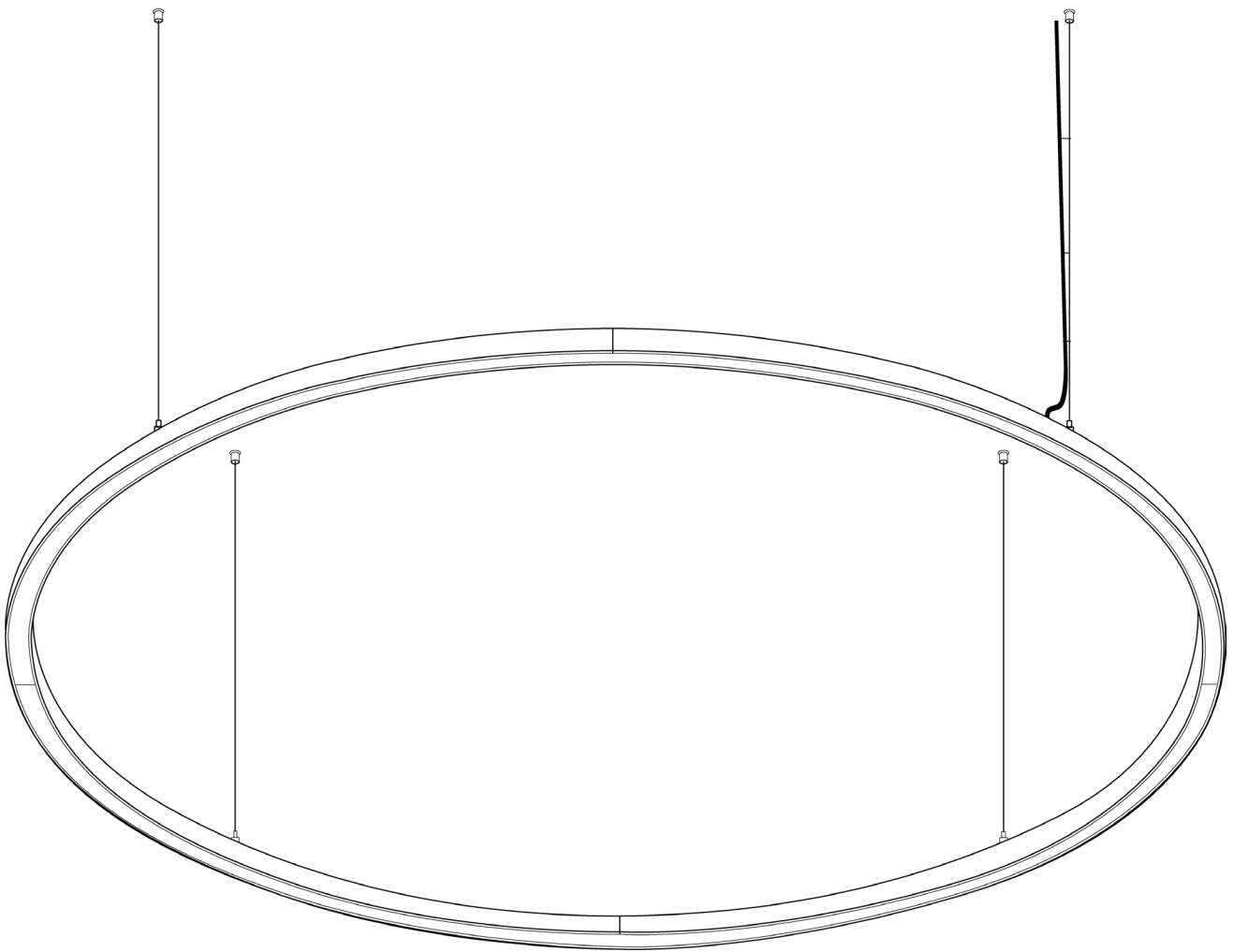

HALO

A Fixed Output.

- Live
- Neutral

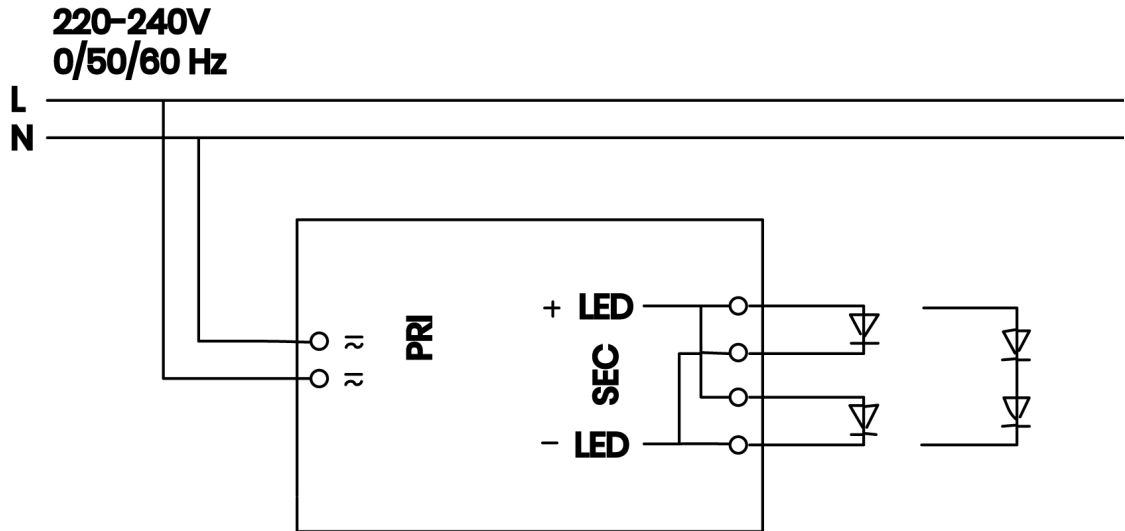

B DALI/DSI Wiring.

- Live
- Neutral
- Earth
- DALI
- DALI

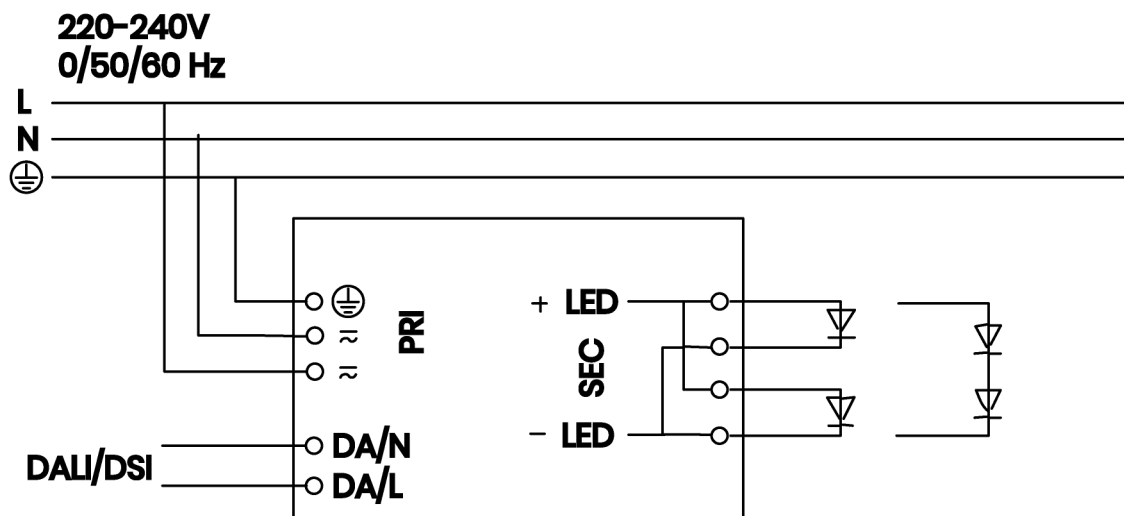

HALO

C

SwitchDIM Wiring.

- Live
- Neutral
- Earth

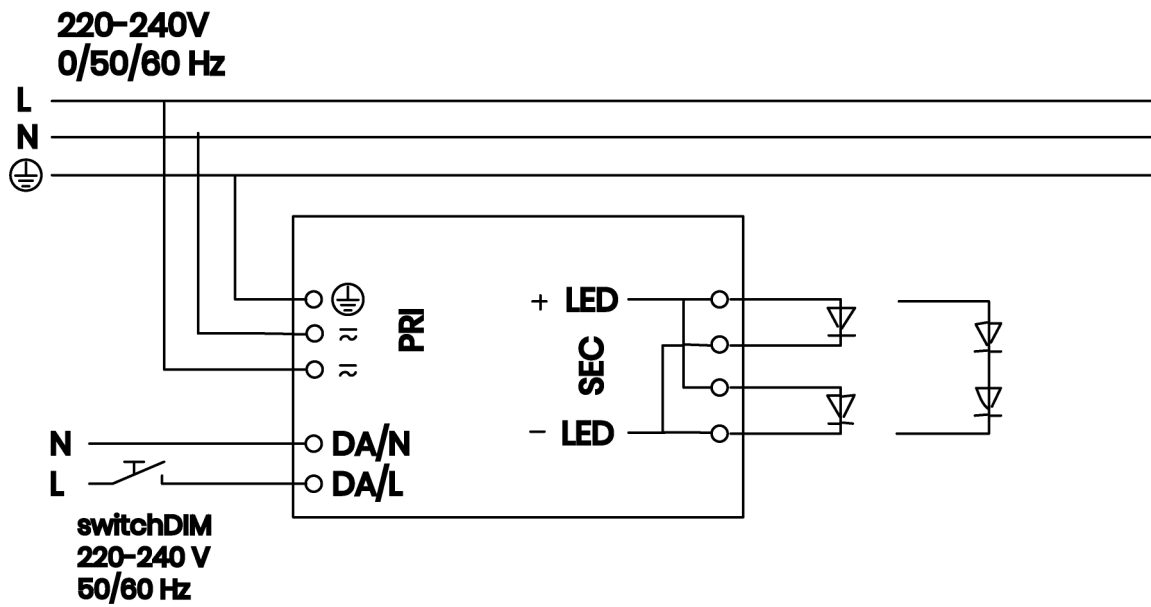

HALO

Safety

- This luminaire should be installed by a qualified electrician in compliance with IEE regulations.
- Please ensure mains supply to luminaire is disconnected before installation or maintenance.
 - The light source contained in this luminaire shall only be replaced by the manufacturer or his service agent or a similar qualified person.

Ratings

- This luminaire is designed to operate at 230VAC
-6% +10% 216v to 252v.
DO NOT OPERATE OUTSIDE THIS RANGE.
- This luminaire is only suitable for installation within its rated ingress Protection limits.

Subject to change without notice. Errors and omission excepted.
Always make sure to use the most recent release.

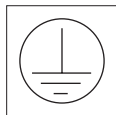
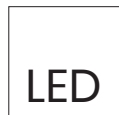

CROWN HOUSE, PLANTATION RD,
BURSCOUGH, LANCASHIRE. L40 8JT
01704 891 333
www.pandaprojects.co.uk